

High pressure research in metals

by B. R. Franko-Filipasic and W. J. McCarthy

The High Pressure Laboratory, Chemical Research & Development Centre, FMC Corporation, P.O. Box 8, Princeton, New Jersey, 08540, USA

Progress in high pressure chemical research has been limited by the inability to operate completely in the metal of choice: all reactor assemblies contain at least two different metal surfaces exposed to the reagents, a fact which the experimenter often does not realise. The common assemblies (Fig. 1) used in research consist of a body (A) and head (B) of

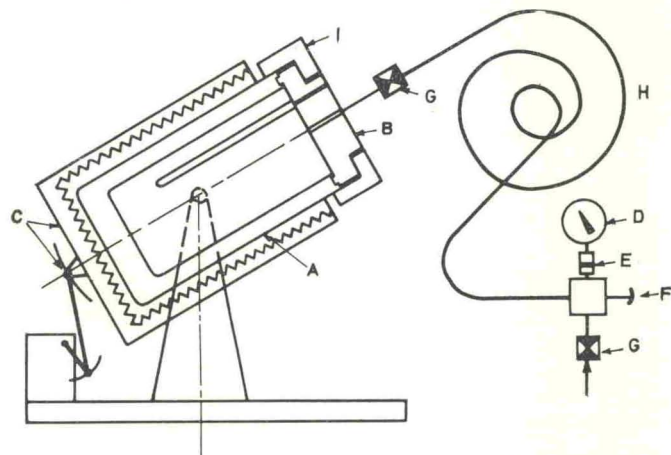

Fig. 1 Reactor schematic (A) body; (B) head; (C) heater-shaker; (D) pressure gauge; (E) gauge isolators; (F) rupture assembly; (G) valve; (H) tubing coil; (I) cap

the same metal housed in an electric heater-shaker unit (C); the pressure gauge (D) and possibly a gauge isolator (E); rupture assembly (F); valves (G); and tubing (H) connected to the gas supply – a flexible connexion, allowing the assembly to shake, is provided by coiling the tubing.

Extraneous metals open to the reagents are found in:

1. *Head and thermowell gaskets.* These gaskets are usually of stainless steel, copper or silver.
2. *Valve closure.* The valve body and stem are usually a type of stainless steel; some other metals are available.
3. *Tubing.* The reactor is connected to valving with stainless steel tubing; very few alternatives are available that are sufficiently flexible and can contain the pressure.
4. *Rupture assembly.* The housing and discs are usually stainless steel, but discs of various metals are available in limited bursting ranges.
5. *Pressure gauge.* The gauge is usually of a Bourdon type of various alloy steels; gauge isolators are stainless steel.

Scrupulous catalytic research under these conditions is a very real problem, especially since the stainless steels in the assembly also vary.

The authors' system has been redesigned to make possible operation in the metal of choice with 'Teflon' as the only extraneous material, by reducing the system to a reactor and a multipurpose valve closure (Fig. 2).

1. The reactor closure has been redesigned to confine a glassfilled 'Teflon' (15/85) gasket (a) in such a way that operations to 400°C and 10,000 psig have been achieved. The gasket is 0.031in thick and 0.25in wide; the clearance between the head ridge and the body groove is 0.005 in. The gasket flows out slightly during operation and must be

replaced after every run. The thermowell gasket (b) is of the same material.

2. A new valve closure has been designed and tested incorporating a rupture assembly (c) and a gauge isolator (d) with a 'Teflon' piston (e). In many reactions where it is not necessary to have a pressure gauge on the reactor, a similar valve without a gauge isolator is used. All process wetted portions of the valve, stem, gauge isolator and rupture assembly are of the metal of choice and 'Teflon'.

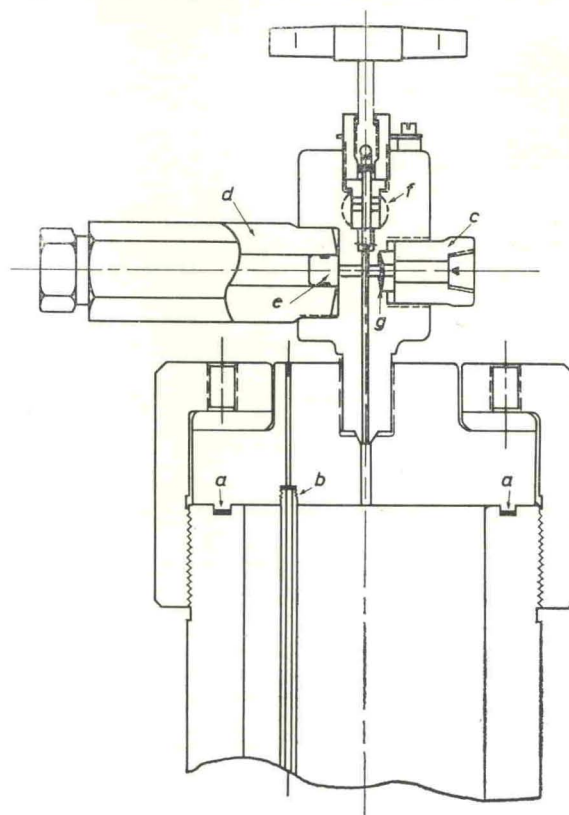

Fig. 2 Multipurpose valve in reactor head (a) head gasket; (b) thermowell gasket; (c) rupture assembly; (d) gauge isolator; (e) 'Teflon' piston; (f) gas connexion; (g) rupture disc

3. No tubing is open to the process, as the valve closure is seated directly in the head. The gas connexion (f) is above the valve stem seat 90° from the rupture assembly.

4. Although rupture discs are available in various metals, the simplest solution is to cover a metallic rupture disc (g) with a 3mm sheet of 'Teflon'. Only under extreme temperature conditions does this fail.

5. The gauge isolator is connected to either a standard gauge or a pressure sensor.

With this system it has been possible to operate in any one type of stainless steel, titanium, aluminium, nickel, Carpenter 20 and various alloys. This equipment was designed and manufactured to the authors' specifications by Pressure Products Industries, Hatboro, Pennsylvania, 19040.

Received 17 August 1970

Revised 23 September 1970